

PLAYING RULES
of the
SPORT OF DARTS

2020

As amended in

Bermuda
September, 2019

Cebille Dawson, Secretary/Treasurer

PLAYING RULES OF THE SPORT OF DARTS

INDEX	PAGE
Glossary of Terms	3
<u>PLAYING RULES</u>	
1. General Rules	4
2. Throw	5
3. Starting and Finishing	5
4. Scoring	6
5. Dartboards	7
6. Oches(Lines)	7
7. Team Registration	8
8. Matches	9
9. Ties,Aggregate, Tons 1001 an league	10
10. Postponement of Matches	11
11. Team withdrawing from the league	11
12. Protest and Violations	11
13. Divisions of the league	12
14. Team knockout Competition	12
15. Presentation and Trophies	12

GLOSSARY OF TERMS USED IN
THE PLAYING RULES AND TOURNAMENT RULES

The following terms shall have the meanings set beside them:-

- PLAYING RULES** - All the rules covering the Sport of Darts as applied to all darts events under the jurisdiction of the BDA. They shall be the playing rules of each member Club and are consistent with the Playing Rules set forward by the World Darts Federation.
- TOURNAMENT RULES** - Those rules applicable to a tournament under the jurisdiction of the BDA.
- REFEREE** - The person appointed to conduct a darts match between two players or two teams in a darts event. He may also be referred to as "Umpire", "Caller", or "Checker". He might also be the scorer.
- SCORER** - The person appointed to make up the score sheets or scoreboards, and make subtractions, adjacent to the matchboard. he may be referred to as the "Marker" or "Chalker". He might also be the referee.
- LEG** - The start and finish of a single game.
- SET** - An odd number of legs forming part of a darts match. "The best of 5 legs"...3-2 or 3-1 or 3-0.
- MATCH** - The total number of legs and sets being competed for between the teams involved.

1. GENERAL RULES

- 1.01 Any matter not expressly covered by the Playing Rules shall be determined by the BDA Executive Body whose decision shall be final and binding.
- 1.02 The Playing Rules of the BDA are those of the WDF except in the cases where no specific rule exists, to the knowledge of the Executive, and the Executive has made a ruling. If the specific rule is, in the future, clarified by the WDF it shall be so changed into the rulings of the BDA.
- 1.03 All players or teams shall play within the Playing Rules of the BDA and, where necessary any supplementary rules laid down by any Association in their own league or events, or by the BDA in its own tournaments and events.
- 1.04 Players shall have their own darts.
- 1.05 Darts shall not exceed 12ins (30.5cm) in length nor weigh more than 50 grams.
- 1.06 Each dart shall consist of a needle shaped point, which shall be fixed to a barrel. At the rear of the barrel there shall be attached a flight stem, which may consist of separate parts.
- 1.07 A throw shall consist of three darts and shall begin when the player sets up at the oche and shall end when he retrieves the darts from the dartboard.
- 1.08 A player may change his darts at any time during a leg, set or match, but not during his throw unless the referee is satisfied that one or more of the darts is broken beyond repair within three (3) minutes.
- 1.09 A player shall be given three (3) minutes in which to throw his three darts. This includes time needed to repair or change flights, shafts or points. Any darts thrown in that throw after three minutes will not count.
- 1.10 Players shall have the right to request a check on the height of the dartboard, the distance from the oche, or the diagonal distance from the board to the oche, prior to the start of the match.
- 1.11 A player shall be called for three (3) times for his game with a two (2) minute wait between calls. Failure to show two (2) minutes after the third call will result in that leg, set or match, whichever is applicable, being forfeited.
- 1.12 During the throw only the player throwing may communicate with the scorer as to score thrown, or remaining.

- 1.13 The scorer may only indicate what is left and not how to finish (32 left, NOT double-16).
- 1.14 No prompting shall be allowed by any person while the player is at the oche. A first offense will be covered by a warning. Any subsequent offense by the same player will result in the forfeiture of that leg.
- 1.15 A player may step back from the oche at any time and confer with anybody.
- 1.16 In all line-ups the order of play shall be the same order as is written down on the score sheet.
- 1.17 If a player throws out of turn in any game, and the error is noticed at any time before the end of that leg, the player, or team, who first threw out of turn shall automatically forfeit that leg, which shall be awarded to the opposing player, or team.”
- 1.18 A player will be allowed six (6) practice darts from the time the referee or scorer calls for the game.

2. THE THROW

- 2.01 A throw shall consist of three (3) darts unless a leg, set or match is finished in less than three darts.
- 2.02 All darts are to be thrown by, and from, the hand.
- 2.03 Any dart bouncing off, or falling out of the dartboard shall not be re-thrown, unless it is the dart thrown to decide on who throws first at the start of a leg, set or match. Such a dart may be re-thrown.
- 2.04 A dart leaving the players throwing hand and traveling over halfway from the oche to the dartboard, shall constitute as a throw and shall not be re-thrown.

3. STARTING AND FINISHING

- 3.01 Every leg must be started by two players throwing for the bull unless tournament or event rules state otherwise.
- 3.02 In matches other than singles any listed player may be the one to throw for the bull.
- 3.03 In matches other than singles, the first player listed will be the one to throw in the game.
- 3.04 When throwing for the bull, closest to the bull goes first. If the first dart thrown hits a single bull or a double bull it shall be removed before the opponent's dart is thrown. If both players hit double bull or both players

hit single bull, then the darts shall be re-thrown, the second player's team now throwing first (i.e. the same person need not re-throw).

- 3.05 Hitting double bull when deciding on who throws first in a game does not constitute the start of a game and does not score.
- 3.06 A game shot called by the referee is valid only if the darts thrown achieve the required finish as stated by the scorer/referee, and remain in the dartboard until retrieved by the thrower after "Game" is called.
- 3.07 Any dart mistakenly thrown by a player, after scoring the required double shall not count, as the respective leg, set or match is concluded by the dart scoring the required double.
- 3.08 Centre Bull (or Double Bull) shall count as 50, or double-25 and may end a game as a double.
- 3.09 The "Bust Rule" shall apply in all games of *-01. That is, if a player scores more than the score required to end a leg then the score reverts back to what it was at the beginning of the throw.

4. SCORING

- 4.01 A dart shall only score if the point remains in, or touches, the face of the dartboard within the outer double wire, and having been called, shall be retrieved from the dartboard by the thrower. If the dart falls out before being retrieved it shall not count, even if the scorer has called it, and the score is amended as necessary.
- 4.02 Darts shall be retrieved from the dartboard, by the thrower, but only after the score has been called by the scorer or referee.
- 4.03 A protest about the score attained after the retrieval of the darts may not be upheld.
- 4.04 If a dart is supported by other darts it shall only score if the point of the dart is touching the dartboard in the part described above, in 4.01.
- 4.05 The score is counted from the side of the segment wire in which the point of the dart enters, and remains in, or touches, the face of the dartboard.
- 4.06 All requests to check the scores recorded, or substitutions made, must be made before the player or team's next throw.
- 4.07 The first player or team to reduce their scores required to exactly zero by obtaining the required double (in games of -01) shall be the winner of that leg, set or match, whichever is applicable.

- 4.08 Any dart travelling over four (4) feet from the throwing line will be counted as thrown.
- 4.09 If a scorer or referee communicates the wrong number required to finish, then that number should be the score left, even if it is wrong, unless an objection is made before the dart is thrown. In such a case the opposing player (team) may make the objection.
- 4.10 When a player asks the scorer for the score remaining, in mid throw, the scorer must write that score, clearly visible, on the scoresheet.
- 4.11 The actual score required must be shown on the score sheet, or score board, clearly visible, in front of the players and the referee.

5. DARTBOARDS

- 5.01 All dartboards shall be of the "Bristle" type.
- 5.02 All dartboards shall be of the 1-20 clock pattern.
- 5.03 The inner narrow band "Treble Ring" which shall score treble the segment number.
- 5.04 The outer narrow band "Double Ring" shall score double the segment number.
- 5.05 The outer centre ring shall score 25.
- 5.06 The inner centre ring "Bull" shall score 50 (or double-25).
- 5.07 The dartboard shall be fixed such that the perpendicular height from the centre of the bull to the floor, at the same level as the oche (line) shall measure 5ft. 8ins. (1.73m).
- 5.08 The four colors of the dartboard shall be:-
Black, Red, Green and off-White (yellow).
- 5.09 The dartboard shall be fixed such that the "20" segment is coloured Black and shall be at the top of the dartboard.

6. OCHES (LINES)

- 6.01 Where possible, a raised oche should be used in all darts games. A raised oche shall be used in all BDA events and tournaments.
- 6.02 A raised oche at least 1 1/2ins. high and 2ft. long (38mm high and 610mm long), must be placed in position at the minimum throwing distance and shall measure from the back of the raised oche 7ft. 9 1/4ins. (2.37m) along the floor to a plumb line at the face of the dartboard.

- 6.03 The diagonal distance from the centre of the bull to the back of the raised oche at floor level shall measure 9ft. 7 1/2ins. (2.93m).
- 6.04 During matchplay no player shall tread on any part of the raised oche, nor shall the player deliver any dart with his feet in any position other than behind the toe edge of the raised oche.
- 6.05 A player wishing to throw a dart, or darts, from a point either side of the raised oche must keep his feet behind an imaginary straight line extending from either side of the raised oche.
- 6.06 Any player in breach of rule 6.04 or 6.05 shall first be warned by the referee. Any dart thrown subsequently, in breach of these rules, shall not score and shall not be re-thrown.
- 6.07 In regular season play, the word "line" may be substituted for "raised oche" in this section.

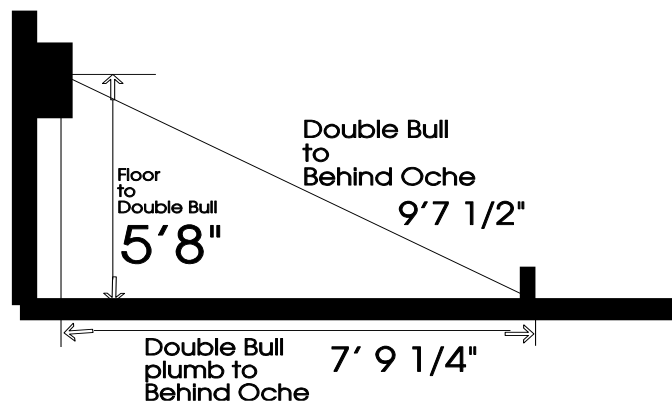

Centre Bull Height.....	5ft.8ins. (1.73m)
Minimum Throwing Distance.....	7ft.9 1/4ins. (2.37m)
Diagonal - Bull to back of Oche.....	9ft.7 1/2ins. (2.93m)
Height of raised Oche.....	1 1/2ins. (38mm)
Width of raised oche.....	2ft. (61cm)

7. Team Registration

- 7.01 Initial team registration at the commencement of the season will only be accepted on the official form of the BDA.
- 7.02 All teams must consist of at least four (4) players a maximum of six (6)
- 7.03 After play in the league has commenced, any team wishing to register additional players must contact the Secretary who must approve registration of the player before they are eligible to play their first

game. The BDA membership of \$20.00 per annum must accompany the scorecard for the game in which the player plays his first game.

7.04 A player having played for any one team in the league shall **NOT** be eligible to play for any team for the remainder of the season, unless written application has been made to the Fixture Secretary and the said transfer approved by Committee.

7.05 If any team shall withdraw from the league, no registered player of such a team shall be eligible for any other team in the league, unless written transfer application has been made to the Fixture Secretary and the said approved by Committee.

7.06 Any team playing a non-registered player in any match shall forfeit all points and any tons scored by the side during said match. The Captain of such defaulting side may be requested to appear before the Committee so that the latter may consider any further action they which to take.

8. Matches

8.01 All league matches shall be played on Monday evenings accept under conditions of rule.

8.02 In league matches the draw shall be made by two-team captains. Each must submit the names of four (4) registered players, no blanks can be used of which three (3) of each team must be present when the draw is made. Once the draw has been made, only one substitute can be made before match time 8:00p.m. Under no circumstances, can a team captain substitute a player who is present and has been drawn initially.

8.03 In all cases the draw must be completed and the first match started by 8:00p.m. (In the event the game does not start at 8:00, the guilty team automatically defaults, unless otherwise agreed by both team captains.) Matches will be played in the order decided by the home captain however: once a sequence is started (I.e. singles) they must be completed before the next sequence.

8.04 All matches will consist of four (4) games. Singles - best two of three (701) legs (501) for one point each, four (4) games doubles - one (1) leg for 1 point each, and one team game of 1001 for a total of nine (9) points.

Under no circumstances can a person play in more than one single game. It is not necessary for the singles players to play in the doubles or 1001. This format will allow teams with more than four players to include them all throughout the evening.

If two playing boards are available to use, the singles can be played at the same time should the team captain's desire.

- 8.05 The 1001 competition **MUST** be played first, substitutes allowed. Flying start, double finish, bust rules apply. Order of play as per scorecard.
- 8.06 Each team captain will ensure that the scorecard is sent to the fixture secretary no later than Wednesday of the same week, no later than 5:00p.m. For the first offence the team will be deducted one (1) point, second offence the team will lose three (3) points and the third offence the Committee will request the captain to appear before them, whose **DECISION** will be final and binding.
- 8.07 Team Captains are responsible for the conduct of their players and guest. During a match players shall conduct themselves in a manner of respect for the other player(s) and shall refrain from annoying the other players or using offensive language or making offensive gestures, and shall refrain from any unsportsmanlike conduct. (I.e. such as deliberately losing a leg or match, deliberately delaying match play, or interfering with the throw of another player).

Any player found by the Organizers to be in breach of this clause shall be deemed to have brought the Sport of Darts into disrepute and shall be disqualified from any further participation in the tournaments or league.

However, if the player, or the officials of the said players team challenge the disqualification, or forfeiture, the matter shall be appealed immediately to the BDA executive, whose **DECISION** shall be final and binding.

All "OPEN" dart tournaments shall be a non-smoking environment.

9. Ties, Aggregate, Tons, 1001 and League

- 9.01 In the event of a tie for first place in the high aggregate on points (i.e. greatest number of legs, should the tie still exist the winner shall be decided by the number of legs, should the tie still exist the winner shall be decided by the least number of legs against. This shall apply in all divisions.
- 9.02 In the event two or more players are tied for the most tons the winner shall be the player who has played the lesser number of games. This shall apply in all divisions.
- 9.03 In the event of a tie in the 1001 competition the winner shall be decided by a play-off. This shall apply for all divisions

9.04 Should a tie exist on completion of the regular league season a play-off will be required on a natural board between the teams concerned. The draw will be made as in the regular league season, but the order of play shall be as the scorecard. Singles and Doubles.

10. Postponement of Matches

10.01 Matches maybe postponed by mutual arrangement of the team captains up to a minimum of seven (7) days. With the exception of the teams effected by the Caribbean cup and World Cup. (team members can be off the island 10 days or more), Any postponement must be arranged at least twenty-four (24) hours before the scheduled time of the match. A new date agreeable to both captains must be arranged at this time and the Fixture Secretary informed. Failure to play a postponed match within the allotted time will result in the guilty team forfeiting such match and each player of the non-offending team will be awarded the game. The BDA shall have the prerogative of withdrawing from the league any team, which has forfeited three(3) or more matches and voiding matches played by such a team, under the rule 11.01, 11.02.

10.02 The BDA has the power to postpone any or all sanctioned dart matches at anytime when deemed necessary.

11. Team withdrawing from the league

11.01 If a team withdraws from the league during the first half of the season, all matches played by such team shall become void in the records of the BDA.

11.02 Should a team withdraw at the commencement of the second half of the season, all matches played during the first half will stand as played, and any matches played during second half become void.

11.03 Any team withdrawing from the league during the playing season shall forfeit their entrance fee and be subject to disciplinary action and/or fined as determined by the BDA.

12. Protest and/or Violations

12.01 Protest and/or violations of the rules shall be forwarded to the Secretary, in writing to bermudadarts@gmail.com or via mail at P.O. Box 513, Hamilton, HM CX within 7 days of the protested match and the nature of the protest shall be fully stated and signed by the team captain.

12.02 The secretary shall inform the non-protesting team of the receipt of the protest received from the protesting team.

- 12.03 Upon receipt of the protest the secretary will call a meeting of the Association and League Committee immediately. Both captains concerned in the match under protest shall be required to attend such meeting.
- 12.04 If both team captains fail to attend such meetings, both shall be fined, or disciplinary action taken, as determined by the committee.
- 12.05 Matches under protest must be completed.

13. Divisions of the League

- 13.01 The BDA reserves the right to rate and place teams, players in the division they deem applicable.
- 13.02 A rated payer is a player playing below his ability as perceived by the Executive Committee.

14. Team Knock Out Competition

- 15.01 Team Knock Out Competition shall involve all teams. Group A, First and Second Division, Group B Third and Fourth Divisions, of the league and shall be played as follows: Five (5) man teams, two (2) of three (3) legs 501 singles, flying start double finish, bust rule applies, games played as per the draw, no substitutes allowed.

15. Presentation and Trophies

- 15.01 The Presentation and allocation of trophies and awards will be held at the end of the season each year.
- 15.02 Should you be eligible for a trophy or award you must be there to collect. In the event you have not informed the Secretary of your non attendance the next person eligible for that same award will be given the award.

The forgoing playing rules have been formulated using the World Dart Federal General playing rules and specification and existing or modified local playing rules as the situation dictated.

